

Zero G

- ✦ **Zero G**
Articulated pneumatic torque reaction arm
Zero Gravity

Zero G

250 - 500 Nm

When useful?

- Heavy weight tools
- High torque power tools
- Wide working area
- It allows to work under chassis
- Both floor and ceiling mounting



Features

- ✓ Handling effort: $\leq 39N$
- ✓ Floor and ceiling installation
- ✓ Pneumatic balancing

Complements:

- + Base extensions
- + Dropper
- + Electromagnetic brakes
- + Positioning system

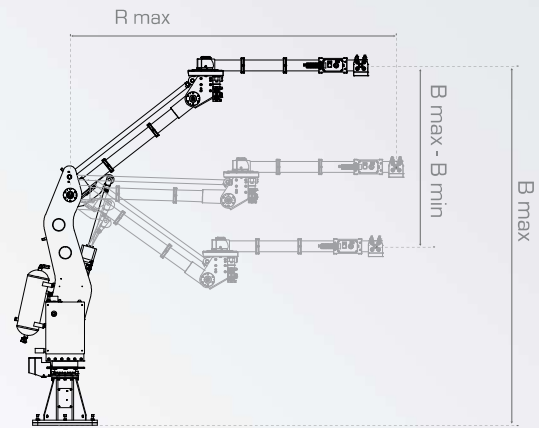

Floor mounting

Descriptions	BNP p/n	Max torque	B max	B max - B min	R max	Payload	Weight
		Nm	Nm	mm	mm	Kg (lb)	Kg (lb)
ZeroG 250-1500	050.0001.000	250	2240	870	1500	55 (121,28)	215 (474,08)
ZeroG 250-2000	050.0002.000	250	2400	1185	2000	45 (99,23)	225 (496,13)
ZeroG 250-2500	050.0003.000	250	2555	1490	2500	35 (77,18)	235 (518,18)
ZeroG 500-1500	050.0201.000	500	2390	870	1500	70 (154,35)	255 (562,28)
ZeroG 500-2000	050.0202.000	500	2545	1185	2000	60 (132,30)	265 (584,33)
ZeroG 500-2500	050.0203.000	500	2700	1490	2500	50 (110,25)	275 (606,38)

Ceiling mounting

		mm	mm	mm	mm	Kg (lb)	Kg (lb)
ZeroG-S 250-1500	050.0051.000	250	2220	870	1500	55 (121,28)	195 (429,98)
ZeroG-S 250-2000	050.0052.000	250	2380	1185	2000	45 (99,23)	205 (452,03)
ZeroG-S 250-2500	050.0053.000	250	2535	1490	2500	35 (77,18)	215 (474,08)
ZeroG-S 500-1500	050.0251.000	500	2370	870	1500	70 (154,35)	240 (529,20)
ZeroG-S 500-2000	050.0252.000	500	2525	1185	2000	60 (132,30)	230 (507,15)
ZeroG-S 500-2500	050.0253.000	500	2680	1490	2500	50 (110,25)	250 (551,25)

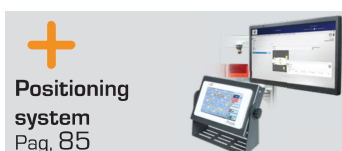



Zero G encoders kit

When useful?

It allows to detect the tool position in the space:

- X, Y and Z axis detection



Descriptions

BNP p/n

ZeroG Encoder Kit

055.0302.000

Features

- ✓ Posix compatible

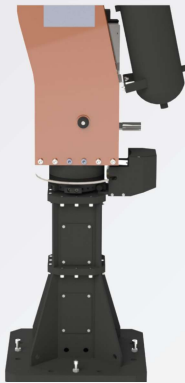

Base extension

When useful?

- Increasing the arm's height



Descriptions

BNP p/n

P/n

Base extension L250

055.0004.000

Base extension L500

055.0005.000

Base extension L1000

055.0006.000

Features

- ✓ Steel made



Dropper

When useful?

An electromagnetic brake can be integrated in order to allow axial rotation.

- Tool position modification
- Axial rotation



Descriptions

BNP p/n

Dropper

050.0101.000

Dropper with electromagnetic brake

050.0102.000

Features

- ✓ Carbon fiber extension with customized tool holder
- ✓ Also available with electromagnetic brake

Installation tips: Zero G

Ex.11: Floor mounted Zero G

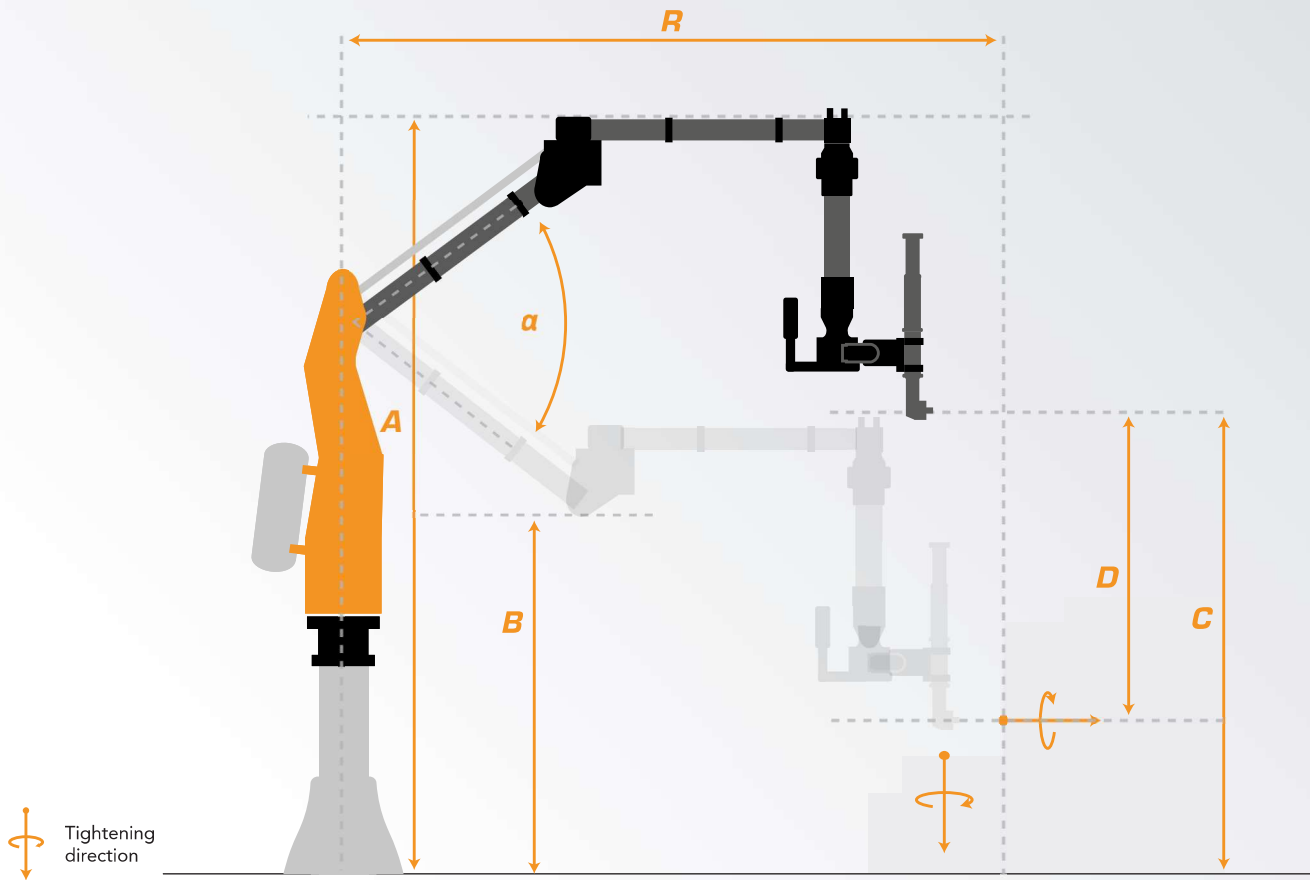

Ex. 12: Ceiling mounted Zero G

